

INSTALLATION INSTRUCTIONS FOR TMPH RAFTER CONNECTOR

U.S. Patent # 5,230,198

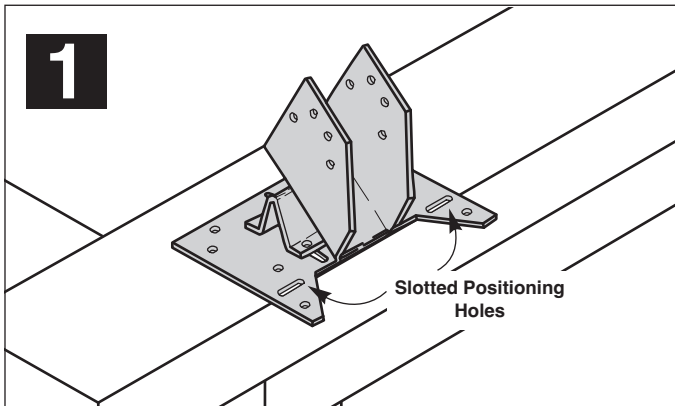

1
Position connector on top plate.
Center outside edge of top plate in slotted positioning holes.

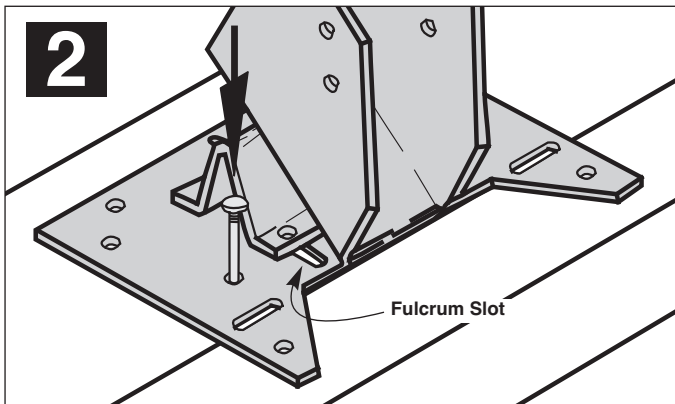

2
Fasten connector to the top of top plate with (6) 10d nails.
NOTE: Do not drive nails through fulcrum slots yet.

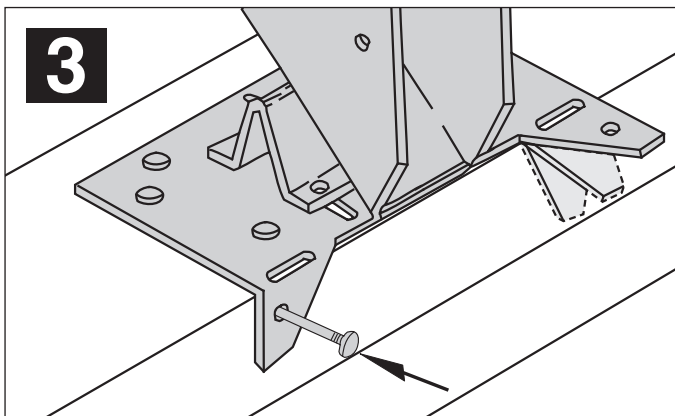

3
Bend tabs downward against edge of top plate.
Fasten with (2) 10d nails.

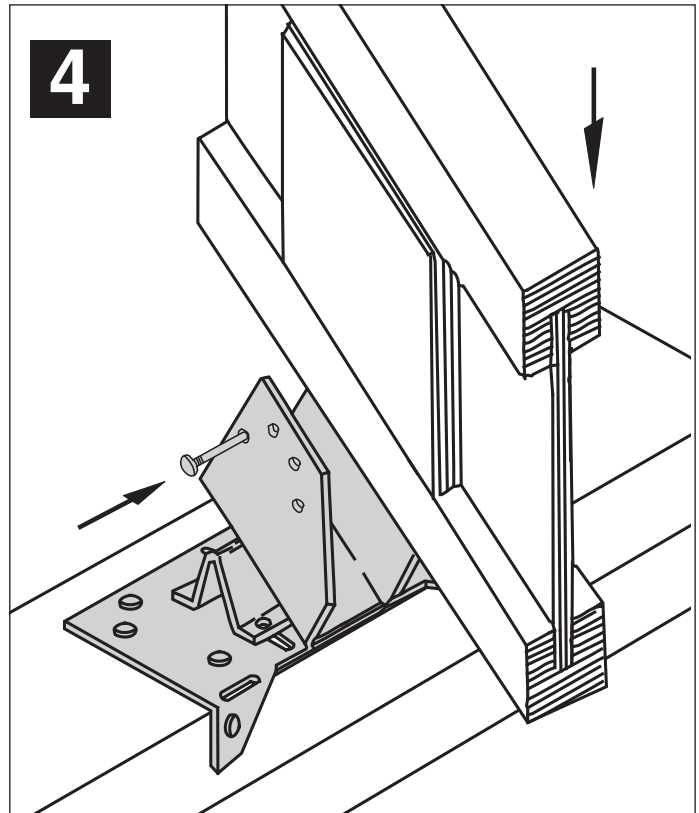

4
Insert rafter into Rafter Pocket. Use downward pressure to fully seat the rafter. Fasten rafter to rafter pocket with (8) 10d x 1-1/2" nails.

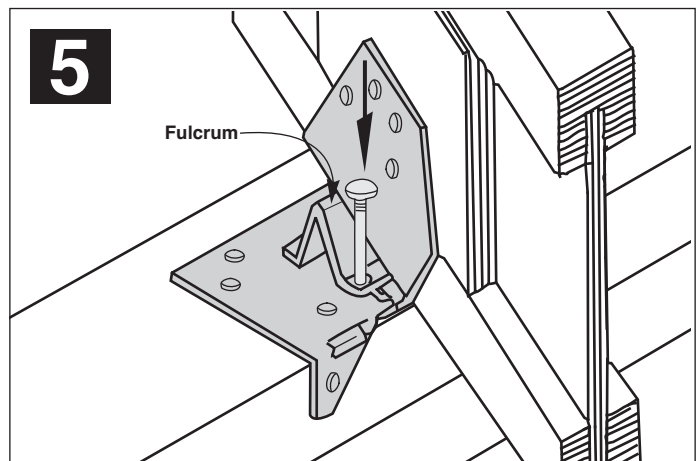

5
Slide fulcrum tight under rafter pocket and secure with (2) 10d nails.
At this point, all nail holes should be filled.

Customer Service:
Burnsville, MN
Phone: 1-800-328-5934
Fax: 1-952-898-8683

Manufacturing:
Montgomery, MN • Livermore, CA
Largo, FL Long Beach, CA
Thornhill, Ontario

Warehouses:
Houston, TX
Lumberton, NJ