

# TOP FLANGE HANGERS TESTED OVER SHEETROCK™

Fire safety in wood structures has become a great concern of builders, building inspectors, and designers / engineers. This has increased the demand for top mount hangers installed on a double top plate covered by Sheetrock™.

USP Structural Connectors® tested our top mount hangers, as used in firewall applications, on a single 5/8" piece of Sheetrock™ over a double DF-L 2 X 4 top plate. The results show allowable load reductions when compared to allowable load values published in USP's current *Full Line Catalog*.

Refer to the allowable load values listed in the chart below.

Several reasons for the allowable load reductions, as observed during testing, are as follows:

- Sheetrock™ crushes much more readily than solid wood. In consequence, the top flange deforms to 1/8" at a lower load than standard solid wood testing.
- The nails installed in the top flange of a top mount hanger are moved closer to the outside edge of the nailer plate. This may cause splitting of the nailer plate to occur at a lower load than normal applications.

The primary cause of failure was due to the crushing of the Sheetrock™ edge. This crushing caused the hangers to deflect earlier than when installed on a solid wood header.

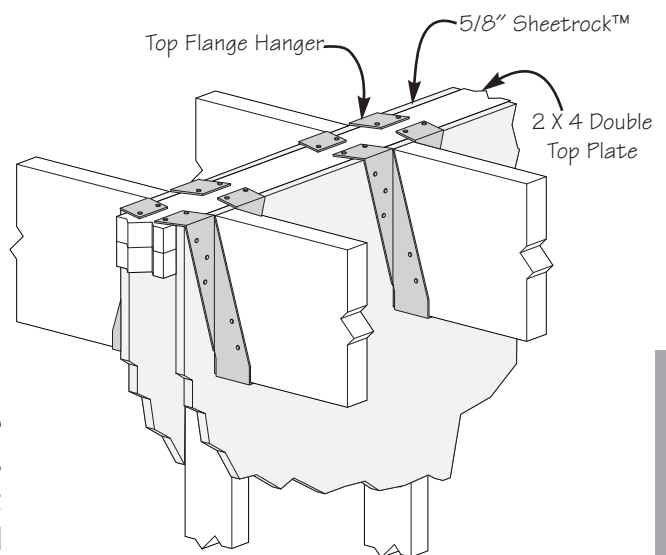

USP Hanger Series	Header Nails <sup>1,2</sup>		Allowable Loads (Lbs.)	
	Top	Face	DF-L / SP <sup>4</sup>	Uplift <sup>3</sup>
			100%	160%
TFL	(4) 10d x 1-1/2	(2) 10d x 1-1/2	1140	295
THO	(4) 10d x 1-1/2	(2) 10d x 1-1/2	1300	295
THO double	(4) 16d	(6) 16d	2500	295
BPH	(4) 16d	(4) 16d	2350	535

- 1) 10d x 1-1/2 nails are 9 gauge (0.148 diameter) by 1-1/2" long.
- 2) Minimum nail embedment shall be 1-5/8" for 16d nails.
- 3) Uplift loads have been increased 60% for wind or seismic loads; no further increase shall be permitted.
- 4) Listed loads shall not be increased.

USP supplies quality products to build Stronger Safer Structures

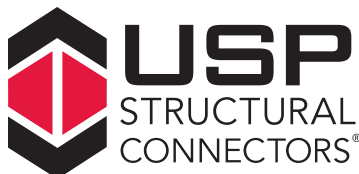

Customer Service:  
Burnsville, MN  
Phone: 1-800-328-5934  
Fax: 1-507-364-8762

Manufacturing:  
Montgomery, MN • Livermore, CA  
Largo, FL • Thornhill, Ontario

Warehouses:  
Houston, TX  
Lumberton, NJ

[www.USPconnectors.com](http://www.USPconnectors.com)

Information valid until January 30, 2011.

A GIBRALTAR INDUSTRIES COMPANY 

USP825-101